

Duration: 3hrs

Max Marks:80

- N.B.: (1) Question No 1 is Compulsory.
 (2) Attempt any three questions out of the remaining five.
 (3) All questions carry equal marks.
 (4) Assume suitable data, if required and state it clearly.

- 1 Attempt any FOUR [20]
 a Differentiate between closed loop control system and open loop control system . [5]
 b Discuss the working principle of Kelvin Double Bridge. [5]
 c What is Impulse response of a system? If Impulse response of a certain system is e^{-5t} . [5]
 Find out transfer function of this system.
 d Define rise time, peak time, maximum overshoot, Delay time, Settling time [5]
 e Compute the transfer function of the given Lag network . [5]

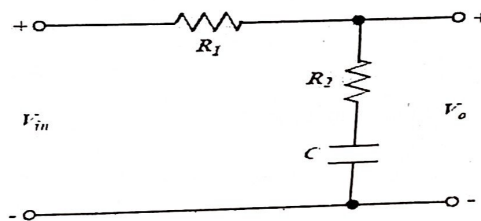

- 2 a Explain with neat diagram principle, construction and working of Strain gauge . Define [10]
 and derive Gauge factor.
 b Determine the overall transfer function $C(S)/R(S)$ for the system shown below using [10]
 block diagram reduction method.

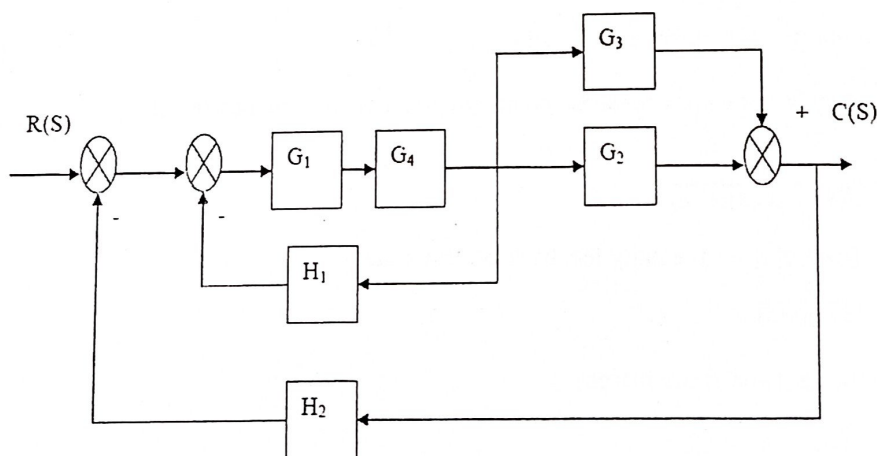

- 3 a For the Signal flow graph shown below, determine the transfer function $C(S)/R(S)$ using Mason's gain formula [10]
Mason's gain formula

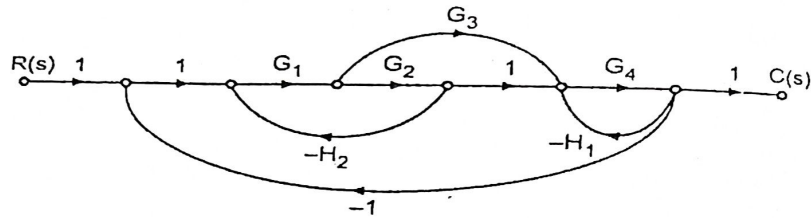

- b A second order system has a unity feedback and open loop transfer function [10]

$$G(s) = \frac{500}{s(s+15)}$$

- i) Calculate T_p , M_p and T_s for system output response when system is excited by unit step input
- ii) Sketch transient response for unit step input
- iii) If input is ramp of 0.5 rad/sec, calculate steady state error

- 4 a The open loop transfer function of a unity feedback control system is given by [10]

$$G(s)H(s) = \frac{s+2}{(s+1)(s+2)}$$

Determine the closed loop stability by Nyquist criterion.

- b Draw the polar plot for the transfer function $G(s) = \frac{10}{(s+2)}$ [10]

- 5 a Plot the root locus for a unity feedback control system has an open loop transfer [10]

$$G(s) = \frac{K}{s(s+1)(s+3)(s+4)}$$

- b Sketch the Bode plot for the unity feedback control system [10]

$$G(s) = \frac{10}{s(s+1)(s+5)}$$

Determine the gain and phase margin

- 6 Attempt any FOUR [5]
- a Write a short note on lag and lead compensators. [5]
- b Write a short note on Hay's Bridge. [5]
- c Write a short note on stability analysis using Nyquist Criteria [5]
- d Use the Rouths stability criterion to determine the range of K for a unity feedback system whose open loop transfer function is [5]
- $$G(s) = \frac{K}{s(s+1)(s+2)}$$
- e State and explain the rules of Block Diagram Reduction in brief. [5]